

HARTON

underground tank & pump system

POD

The hidden space saver

The Harton **POD**, **MiniPOD** and **MaxiPOD** are complete WRAS-approved tank and pump assemblies with their own plant room – all located fully below ground, with a system-monitoring panel sited elsewhere which can be linked to a telephone autodialler, computerised Building Management System or additional on-site alarms.

PODs, **MiniPODs** and **MaxiPODs** can be sited under any free area, even below a car park, thus maximising valuable above-ground usable space and avoiding the need for an expensive separate building.

Harton **POD**, **MiniPOD** and **MaxiPOD** underground units are available with a range of storage capacities and pump combinations sufficient to provide guaranteed pressure and flow rates for potable water systems in major commercial or residential developments, right down to small schemes with a few dwellings.

They are built to the same demanding standards as the comprehensive tried-and-tested range of above-ground pump and booster combinations which Harton supply to major developers and are delivered to site with the plant room fully wired and plumbed and with all safety features factory fitted.

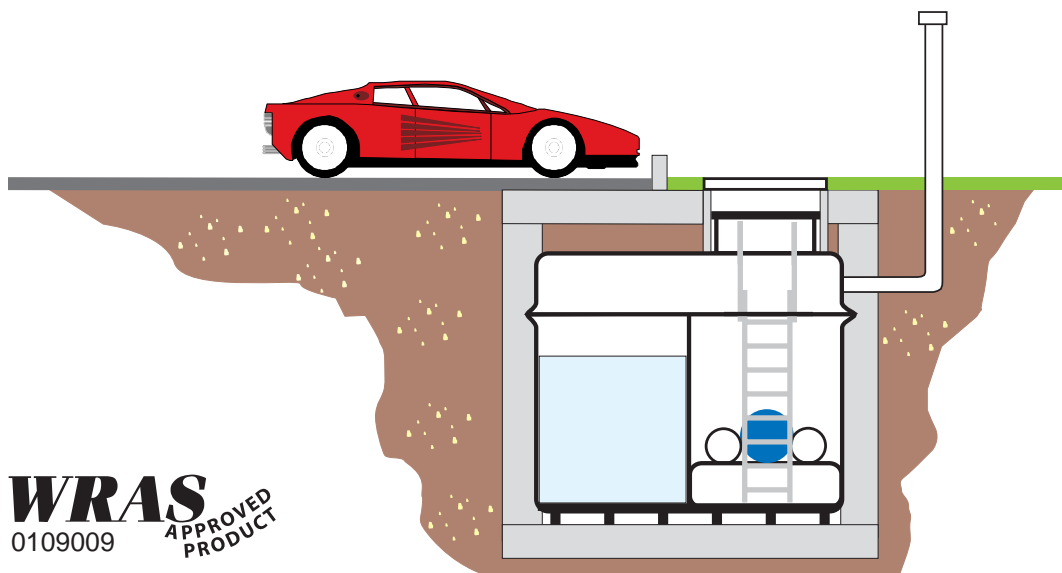

Harton Heating Appliances Limited

Unit 6, Thistlebrook Industrial Estate Abbey Wood, London SE2 9RB
Tel 020 8310 0421 Fax 020 8310 6785 www.hartons.co.uk

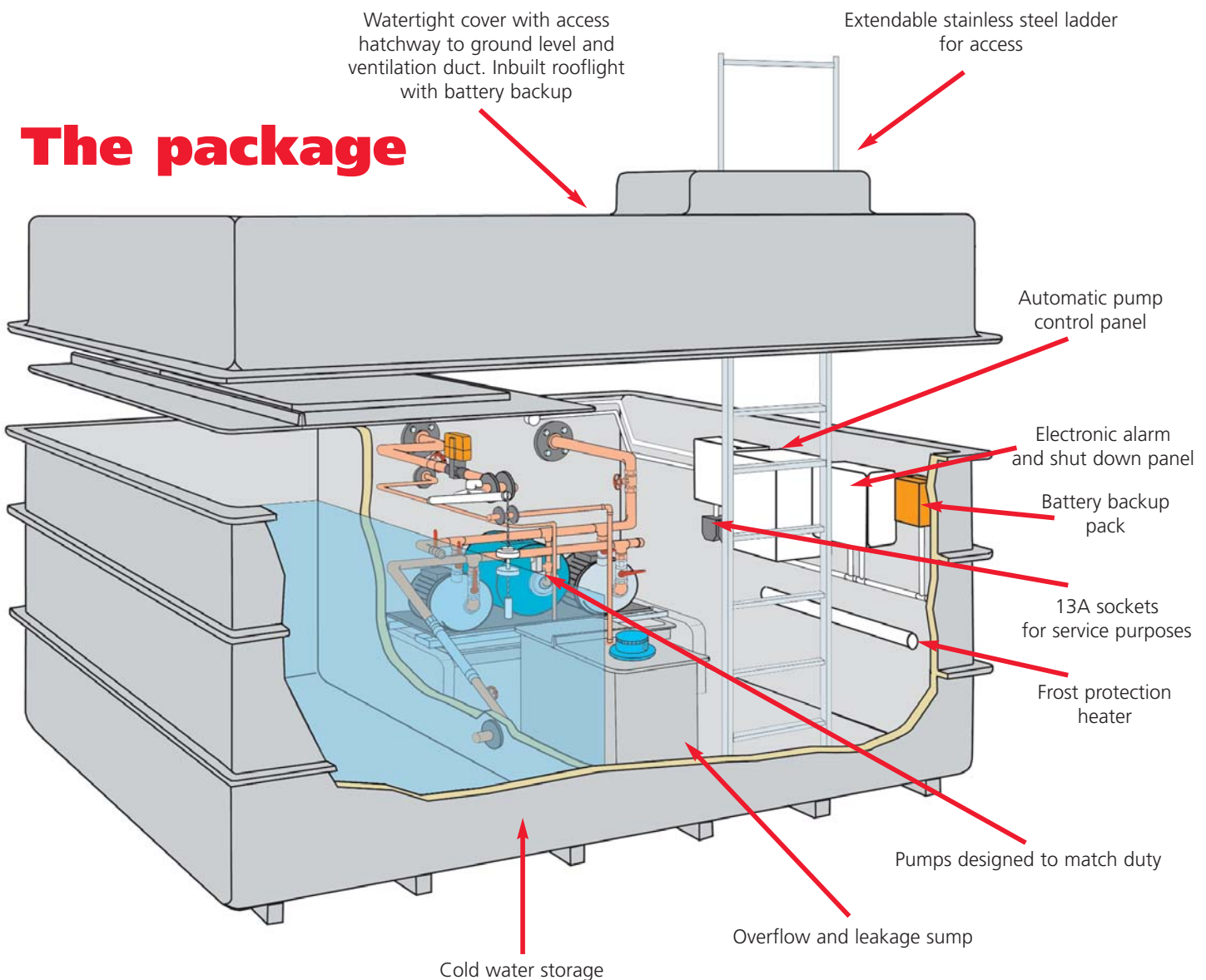

The technicalities

Harton **POD**, **MiniPOD** and **MaxiPOD** underground tank and pump systems are complete enclosed packages for siting fully below ground, with watertight enclosures and top access hatches accessible via loadbearing manhole covers at ground level.

The units are lowered onto a precast base and the construction of the units permits a concrete backfill to be poured directly around the housings in two stages. The unit is not designed for load carrying, therefore the base, concrete backfill and top span covering must be designed to withstand expected surface loadings from above.

Capacities, dimensions and approximate weights are:

POD: 2600 litres water -
2700mm X 2200mm X 2500mm high -
1000kg empty / 4000kg full

MiniPOD: 1100 litres water -
1700mm X 2200mm X 2500mm high -
850 empty / 2000kg full.

150mm clearance must be left above each hatchway plus the thickness of a suitable load-bearing manhole cover at ground level.

MaxiPODs have larger water storage capacities and comprise underground water storage modules linked to a separate underground plant room. They are individually designed to suit specific applications.

Storage sections on **PODs**, **MiniPODs** and **MaxiPODs** are fitted with either a 42mm or 50mm high-flow float valve depending on system demand.

PODs, **MiniPODs** and **MaxiPODs** have a separate plant room section which houses multiple boosting pumps individually designed to suit site requirements. Pumps are fitted with anti-vibration connections and mountings and a tank-mounted low-water float switch in each water storage section protects the pumps against dry running.

The plant room also houses other fully fitted, pre-plumbed, pre-wired and factory tested equipment including a bulkhead light with battery backup, a frost protection heater with thermostat, twin 13A sockets for maintenance purposes and all necessary safety and cutout equipment. A stainless steel access ladder with safety extension is fitted as standard in each plant room and **MaxiPOD** storage module.

External pipe connections

The following fittings are on the outside of the housing for site connection and all except the air vent connection are grouped so that they can be located within a separate access chamber:

Mains water inlet: BSPF 2", 2½" or 3" depending on system loading

Pumped water outlet: BSPF 2", 2½" or 3" depending on system loading. Some **MaxiPODs** may have a larger sized pumped outlet.

Sump pump discharge: 1¼" BSPF for connection of sump pump discharge pipe to be run to a physically protected and flood-free position above ground.

Air vent: 108mm for connection to an external vent at a physically protected and flood-free position above ground.

Monitoring and alarm system

A remote wall mounted system monitoring panel is supplied with each unit for siting at a convenient above-ground location. This indicates by means of coloured lamps "SYSTEM ON" plus any or all of three alarm conditions and also provides four volt-free pairs of contacts for connection to any other external monitoring system, such as a telephone autodialler, a Building Management System or to additional on-site alarms.

An electronic control system within the underground tank and pump unit detects water overflows or water from leakage or other sources and transmits this information to the remote system monitoring panel and to any external alarm system.

Where the quantity of water is significant, such as may be caused by a jammed float valve, the electronic controls automatically shut down the incoming water supply, activate a red alarm lamp on the remote panel and switch on a sump emptying pump which discharges above ground. The incoming water supply can then only be restored by manual resetting within the underground unit, thus ensuring that the cause of the fault will be properly investigated and rectified before the water supply is restored.

Pumped supply continues with mains off

Although the mains water inlet is shut down when significant water quantities appear, the main pumps continue to operate until the storage in the main tank is used up and a low-level switch shuts off the pumps. This provides some continuity of supply for a period before the fault is rectified and the mains supply is reinstated.

No shutdown for minor leakage

For smaller quantities of water appearing in the sump from minor leakages, such as from the pumps or slow letby from the float valve, the electronic unit first activates an amber lamp on the remote monitoring panel indicating that attention is needed, but does not close down the mains inlet valve and therefore leaves the system in full operation. Mains shut down then only occurs if the water continues to build up to a higher level.

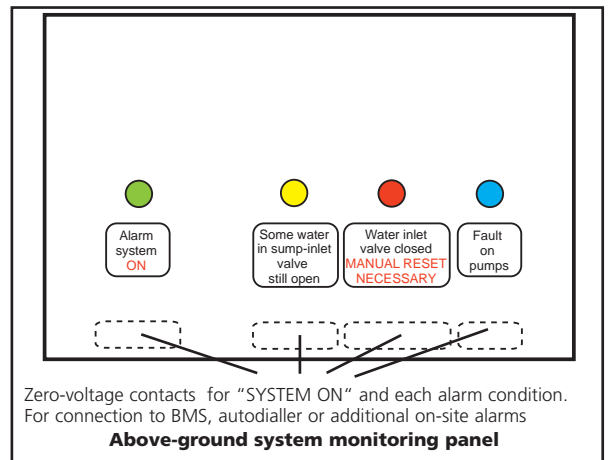

Auto-reset after power failure

On failure of the mains electrical supply the electronic controls automatically shut down the incoming mains water supply and activate both water sensing alarms. However, in the absence of any water in the sump, the system is automatically restored to normal operating condition once the power is reinstated, thus avoiding unnecessary callout.

Electrical connections

Mains electrical supply:

A two metre length of electrical cable extends outside the housing for the site connection of single- or three-phase mains supply to the unit, including to the pumps. This cable is factory prewired to an isolator and safety cutout panel and to all the internal mains electrical accessories inside the housing. The total electrical loading depends on the pump duty.

System monitoring connections:

A separate two metre length of five-core electrical cable extends outside the housing for connection to the 24V low-current remote monitoring panel located above ground. This cable is factory prewired to all necessary alarm connections inside the housing. For easy identification, each cable core is colour coded to match the terminal markings in the above-ground monitoring panel.

Telephone autodialler or BMS

The external system monitoring panel is fitted with four pairs of volt free connections for "SYSTEM ON" plus each of the three alarm conditions. These connections can be linked to a telephone autodialler (supplied as an option) which automatically dials three chosen numbers in sequence and transmits the site location plus details of any fault condition(s). They can also be used for interface with a Building Management System or to activate additional on-site alarms.

